

18 W hi-fi amplifier and 35 W driver

Features

- Output power 18 W at $V_S = \pm 16\text{ V} / 4\ \Omega$ with 0.5% distortion
- High output current
- Very low harmonic and crossover distortion
- Short-circuit protection
- Thermal shutdown

Description

The TDA2030A is a monolithic IC in a Pentawatt package intended for use as a low-frequency class-AB amplifier.

With $V_{S\text{max}} = 44\text{ V}$ it is particularly suited for more reliable applications without regulated supply and for 35 W driver circuits using low-cost complementary pairs.

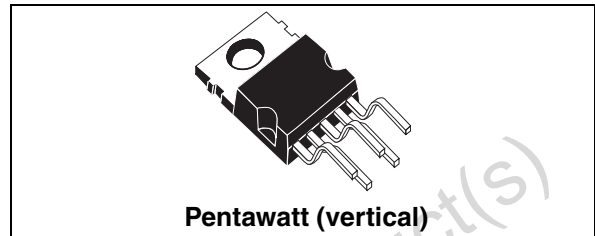

Pentawatt (vertical)

The TDA2030A provides high output current and has very low harmonic and crossover distortion. The device incorporates a short-circuit protection system comprising an arrangement for automatically limiting the dissipated power so as to keep the operating point of the output transistors within their safe operating range. A conventional thermal shutdown system is also included.

Table 1. Device summary

Order code	Package
TDA2030AV	Pentawatt (vertical)

Figure 1. Typical application

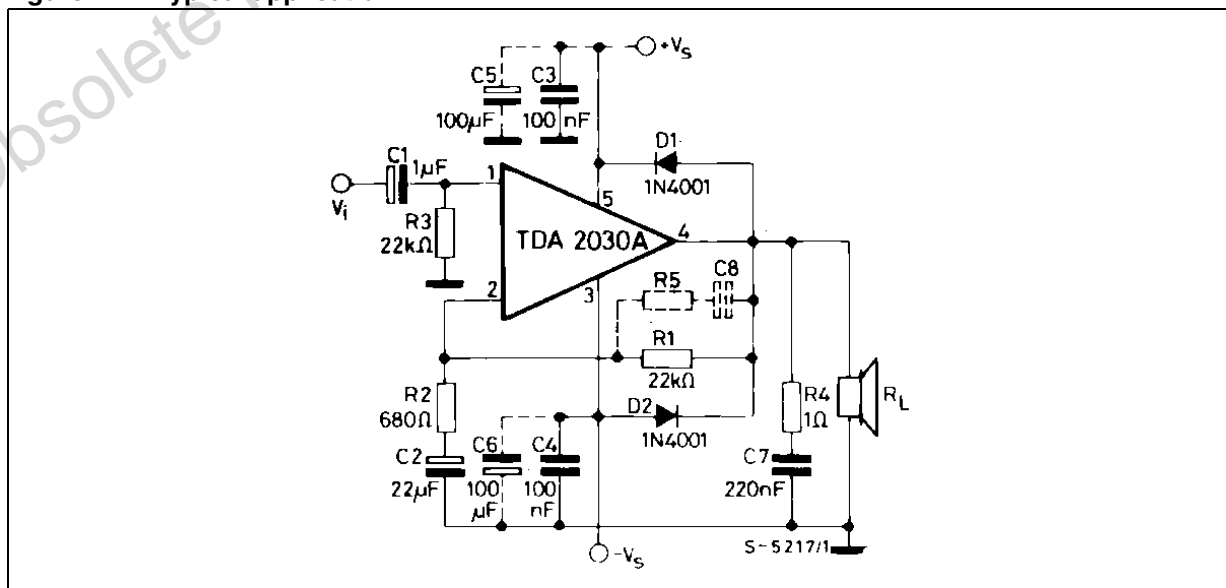

1 Device overview

Figure 2. Pin connections (top view)

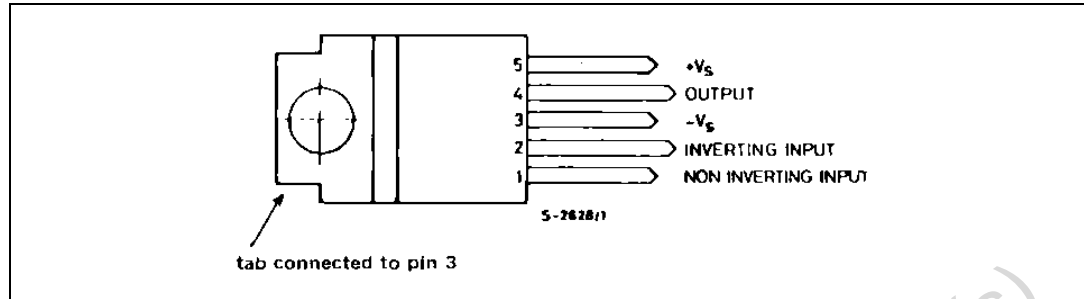

Figure 3. Test circuit

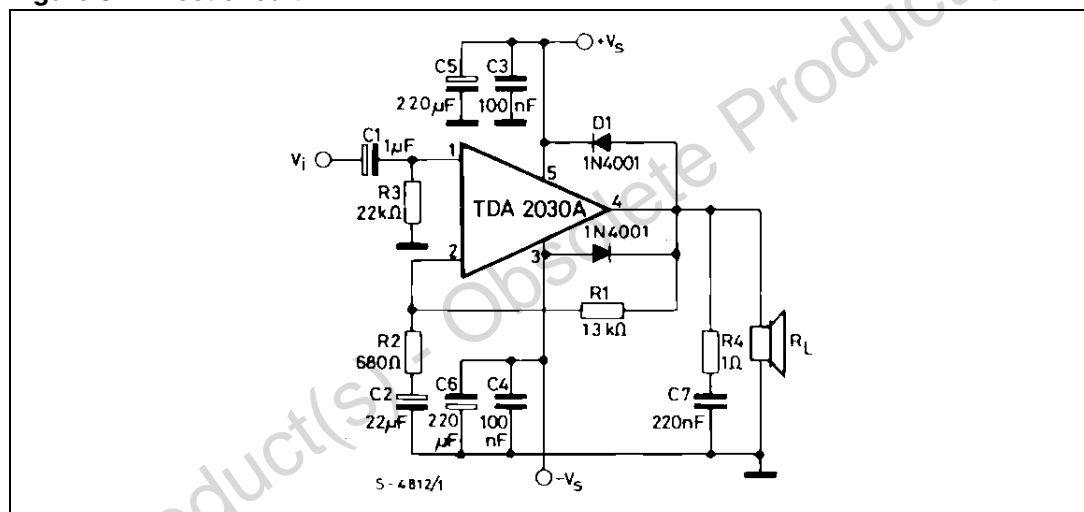

Table 2. Thermal data

Symbol	Parameter	Value	Unit
$R_{th(j-case)}$	Thermal resistance junction-case	max. 3	°C/W

Table 3. Absolute maximum ratings

Symbol	Parameter	Value	Unit
V_s	Supply voltage	± 22	V
V_i	Input voltage	V_s	
V_i	Differential input voltage	± 15	V
I_o	Peak output current (internally limited)	3.5	A
P_{tot}	Total power dissipation at $T_{case} = 90\text{ °C}$	20	W
T_{stg}, T_j	Storage and junction temperature	- 40 to + 150	°C

Table 4. Electrical characteristics(Refer to the test circuit, $V_S = \pm 16\text{ V}$, $T_{\text{amb}} = 25\text{ °C}$ unless otherwise specified)

Symbol	Parameter	Test condition	Min.	Typ.	Max.	Unit
V_S	Supply voltage		± 6		± 22	V
I_d	Quiescent drain current			50	80	mA
I_b	Input bias current	$V_S = \pm 22\text{ V}$		0.2	2	μA
V_{os}	Input offset voltage	$V_S = \pm 22\text{ V}$		± 2	± 20	mV
I_{os}	Input offset current			± 20	± 200	nA
P_O	Output power	$d = 0.5\%$, $G_v = 26\text{ dB}$ $f = 40\text{ to }15000\text{ Hz}$ $R_L = 4\ \Omega$ $R_L = 8\ \Omega$ $R_L = 8\ \Omega$ $V_S = \pm 19\text{ V};$	15 10 13	18 12 16		W
BW	Power bandwidth	$P_O = 15\text{ W};$ $R_L = 4\ \Omega$		100		kHz
SR	Slew rate			8		V/ μsec
G_v	Open loop voltage gain	$f = 1\text{ kHz}$		80		dB
G_v	Closed loop voltage gain	$f = 1\text{ kHz}$	25.5	26	26.5	dB
d	Total harmonic distortion	$P_O = 0.1\text{ to }14\text{ W};$ $f = 40\text{ to }15\ 000\text{ Hz};$ $P_O = 0.1\text{ to }9\text{ W}, f = 40\text{ to }15\ 000\text{ Hz}$ $R_L = 8\ \Omega$ $R_L = 4\ \Omega$ $f = 1\text{ kHz}$		0.08 0.03 0.5		%
d_2	Second order CCIF intermodulation distortion	$P_O = 4\text{ W}, f_2 - f_1 = 1\text{ kHz}, R_L = 4\ \Omega$		0.03		%
d_3	Third order CCIF intermodulation distortion	$f_1 = 14\text{ kHz}, f_2 = 15\text{ kHz}$ $2f_1 - f_2 = 13\text{ kHz}$		0.08		%
e_N	Input noise voltage	B = Curve A B = 22Hz to 22kHz		2 3	10	μV μV
i_N	Input noise current	B = Curve A B = 22Hz to 22kHz		50 80	200	pA pA
S/N	Signal-to-noise ratio	$R_L = 4\ \Omega, R_g = 10\text{ k}\Omega, B = \text{Curve A}$ $P_O = 15\text{ W}$ $P_O = 1\text{ W}$		106 94		dB dB
R_i	Input resistance (pin 1)	(open loop) $f = 1\text{ kHz}$	0.5	5		M Ω
SVR	Supply voltage rejection	$R_L = 4\ \Omega, R_g = 22\text{ k}\Omega$ $G_v = 26\text{ dB}, f = 100\text{ Hz}$		54		dB
T_j	Thermal shutdown junction temperature			145		$^{\circ}\text{C}$

Figure 4. Single supply amplifier

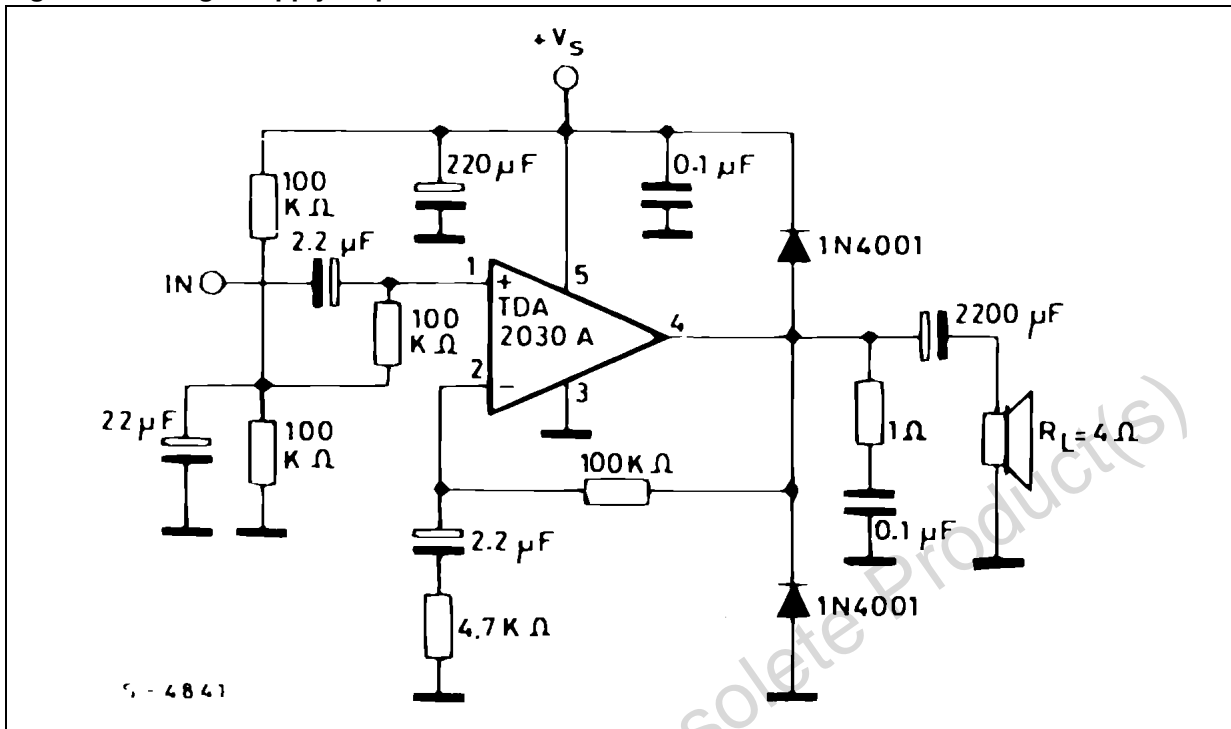

Figure 5. Open loop-frequency response

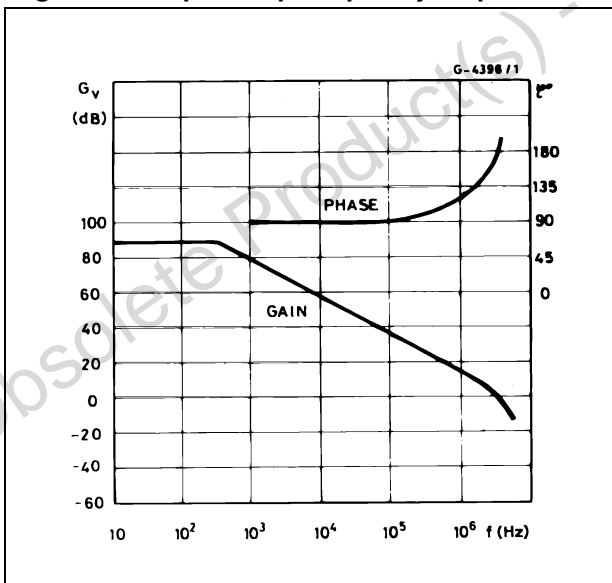

Figure 6. Output power vs. supply voltage

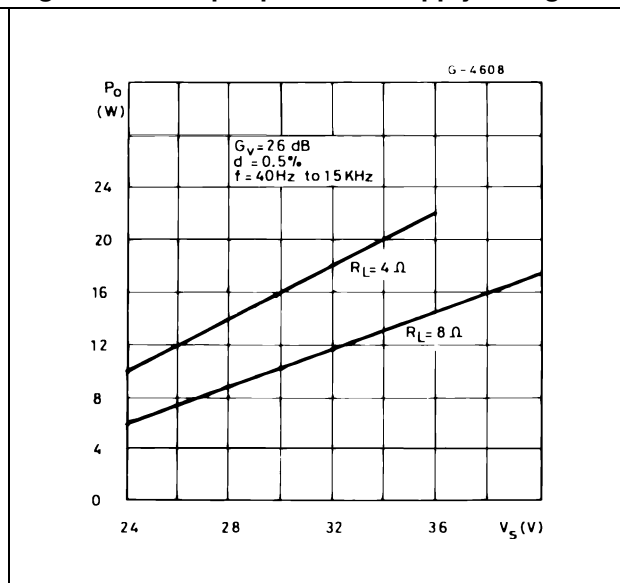

Figure 7. Total harmonic distortion vs. output power (test using rise filters)

Figure 8. Two-tone CCIF intermodulation distortion

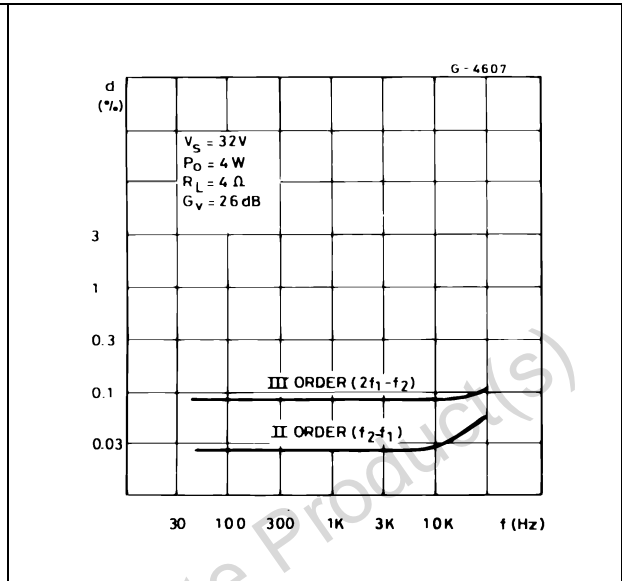
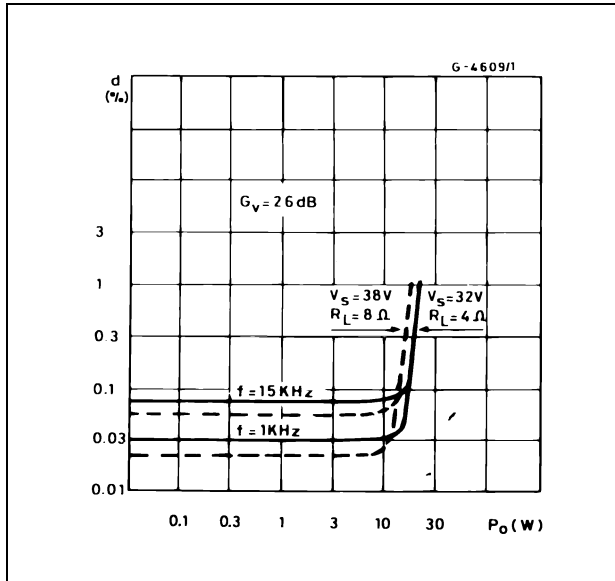

Figure 9. Large signal frequency response

Figure 10. Maximum allowable power dissipation vs. ambient temp.

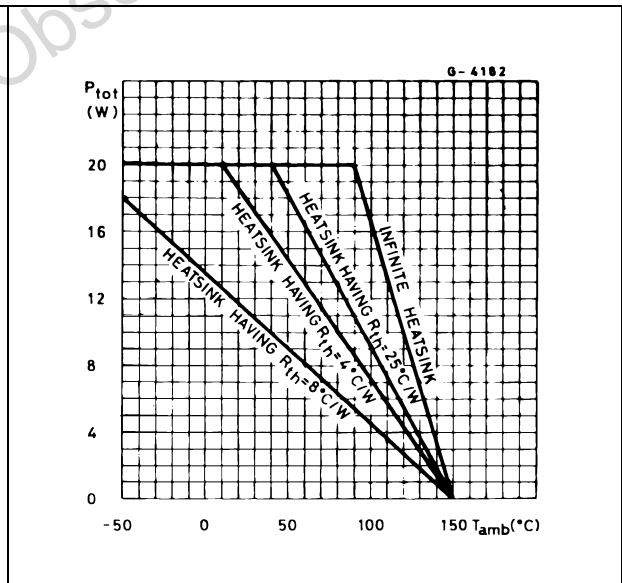
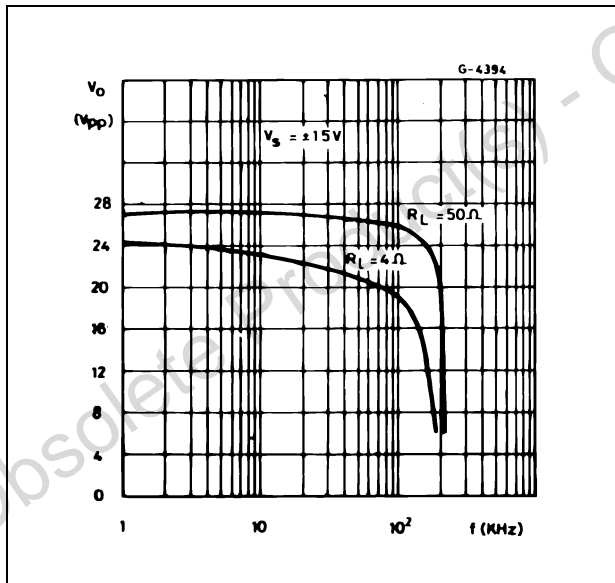

Figure 11. Output power vs. supply voltage

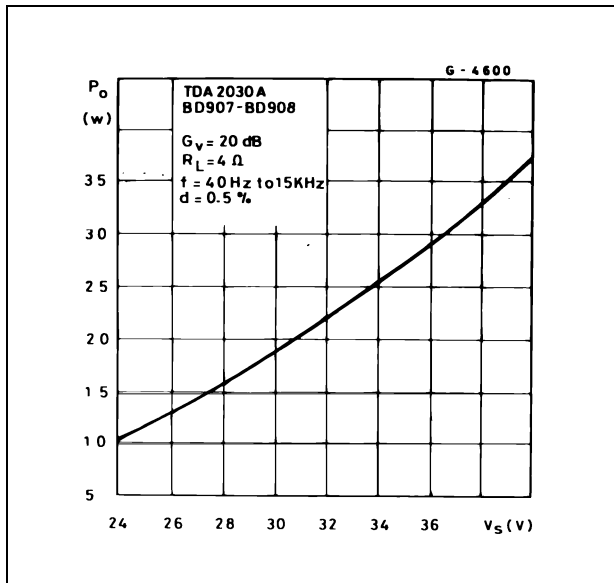

Figure 12. Total harmonic distortion vs. output power

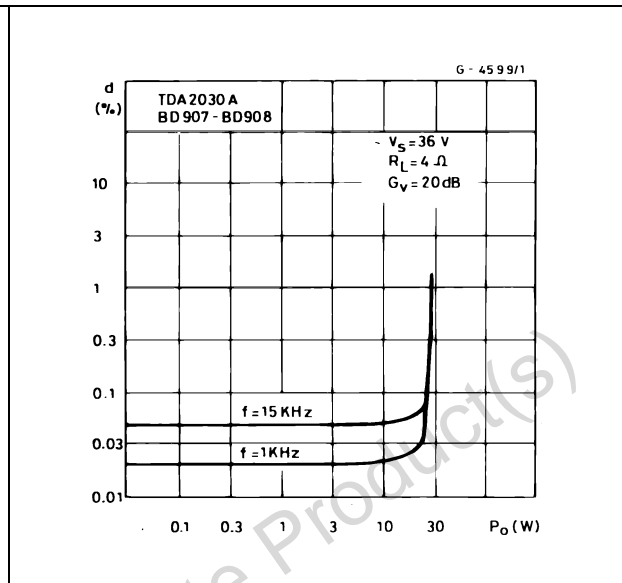

Figure 13. Output power vs. input level

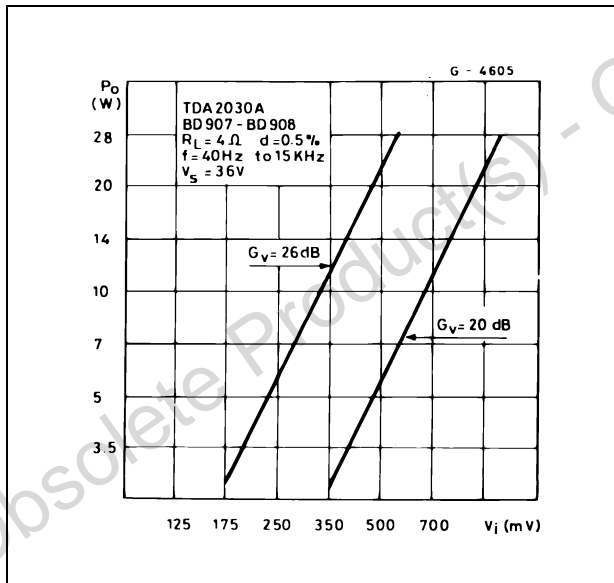

Figure 14. Power dissipation vs. output power

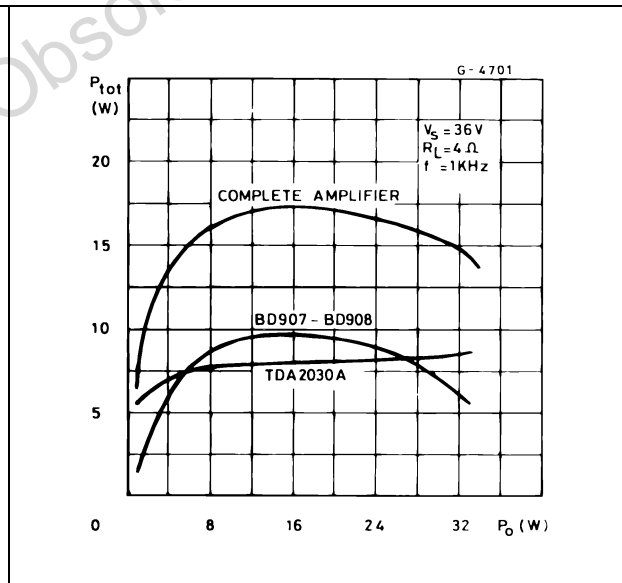

Figure 15. Single-supply high-power amplifier (TDA2030A + BD907/BD908)

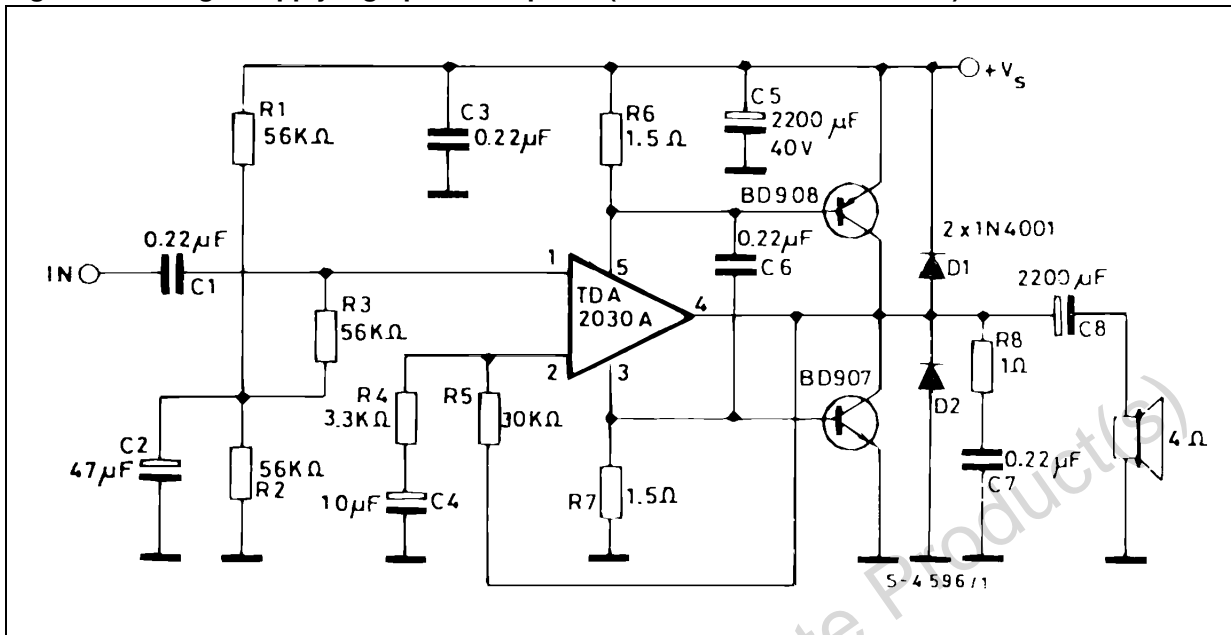

Figure 16. PC board and component layout for the single-supply high-power amplifier

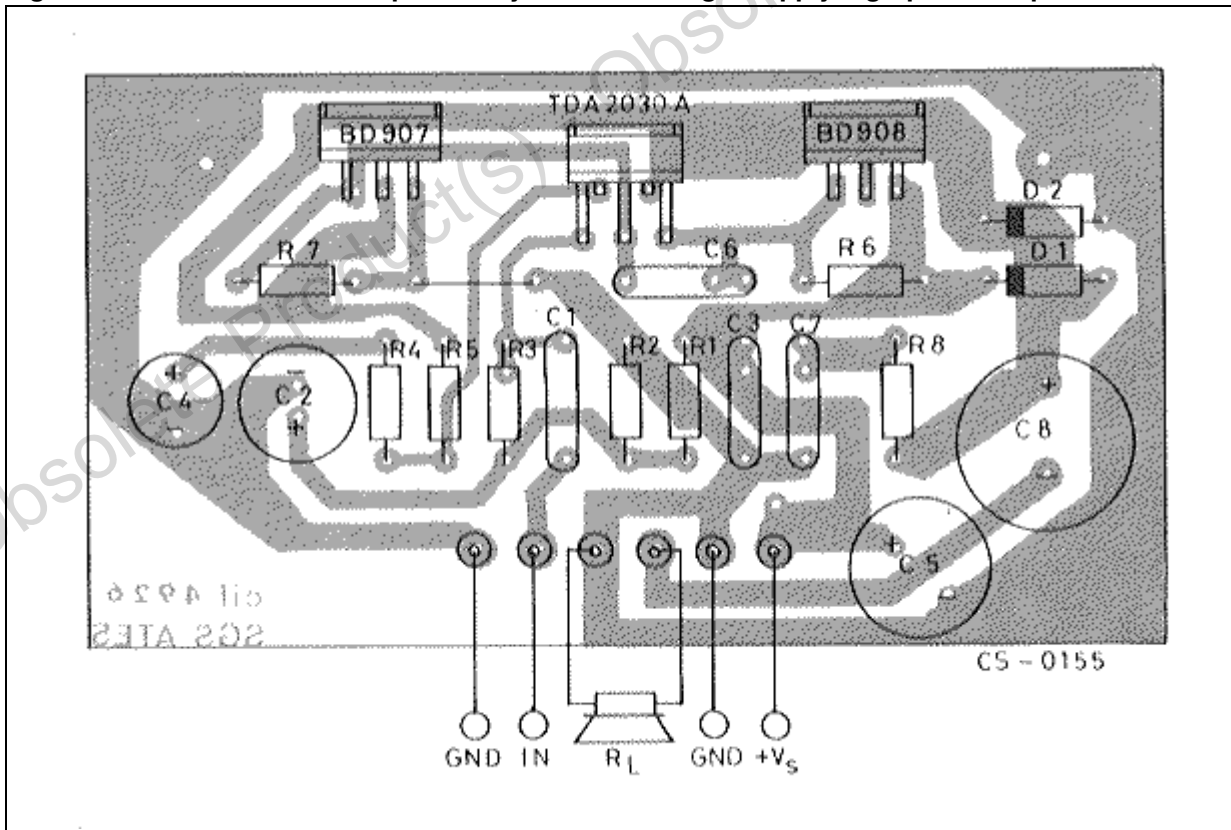

Table 5. Typical performance of the single-supply high-power amplifier

Symbol	Parameter	Test conditions	Min.	Typ.	Max.	Unit	
V_s	Supply voltage			36	44	V	
I_d	Quiescent drain current	$V_s = 36\text{ V}$		50		mA	
P_o	Output power	$d = 0.5\%$, $R_L = 4\ \Omega$, $f = 40\text{ Hz to }15\text{ kHz}$		$V_s = 39\text{ V}$		35	W
				$V_s = 36\text{ V}$		28	W
		$d = 10\%$, $R_L = 4\ \Omega$, $f = 1\text{ kHz}$		$V_s = 39\text{ V}$		44	W
				$V_s = 36\text{ V}$		35	W
G_v	Voltage gain	$f = 1\text{ kHz}$	19.5	20	20.5	dB	
SR	Slew rate			8		V/ μs	
d	Total harmonic distortion	$f = 1\text{ kHz}$		0.02		%	
		$P_o = 20\text{ W}$; $f = 40\text{ Hz to }15\text{ kHz}$		0.05		%	
V_i	Input sensitivity	$G_v = 20\text{ dB}$, $f = 1\text{ kHz}$, $P_o = 20\text{ W}$, $R_L = 4\ \Omega$	890			mV	
S/N	Signal-to-noise ratio	$R_L = 4\ \Omega$, $R_g = 10\text{ k}\Omega$, B = Curve A		108		dB	
			$P_o = 25\text{ W}$ $P_o = 4\text{ W}$	100		dB	

Figure 17. Typical amplifier with split power supply

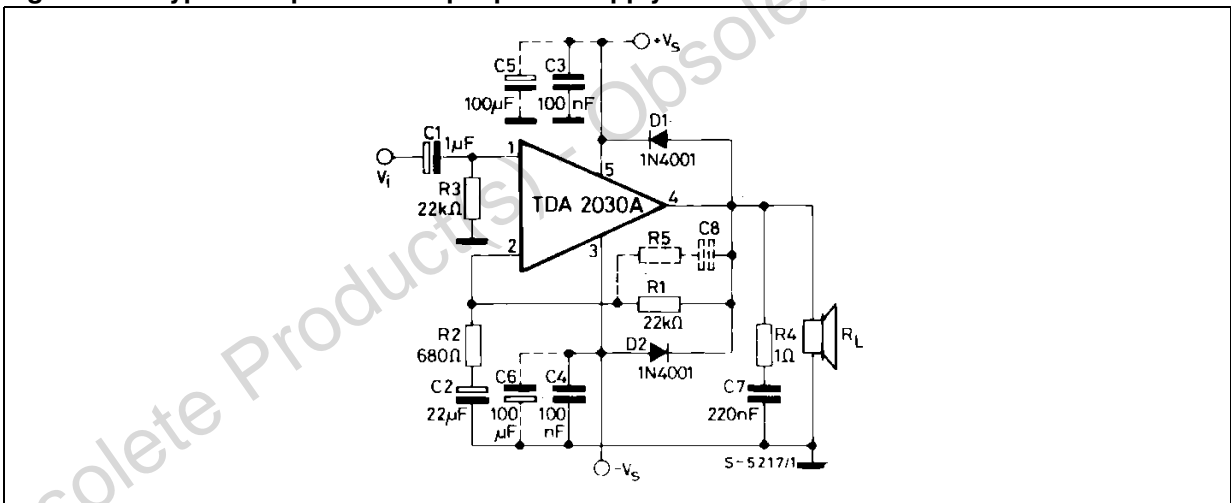

Figure 18. PC board and component layout for the typical amplifier with split power supply

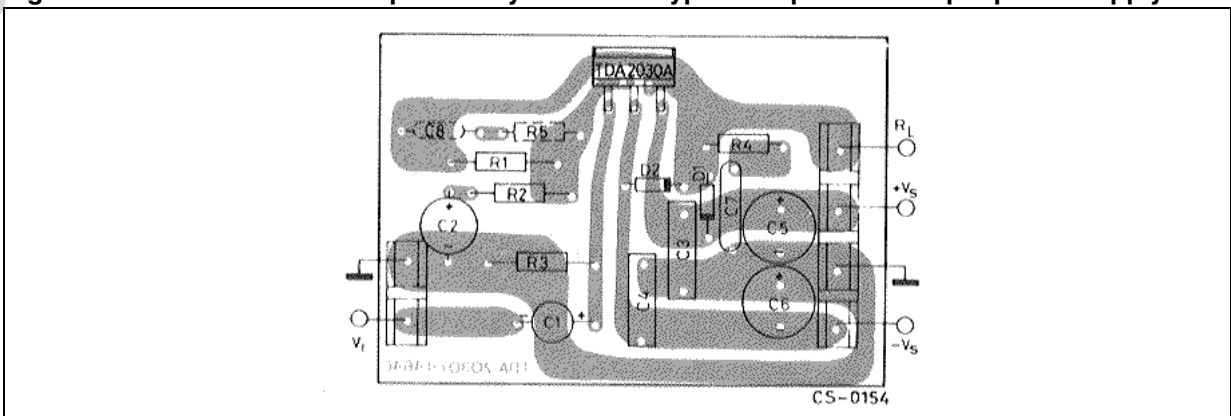

Figure 19. Bridge amplifier with split power supply ($P_O = 34\text{ W}$, $V_S = \pm 16\text{ V}$)

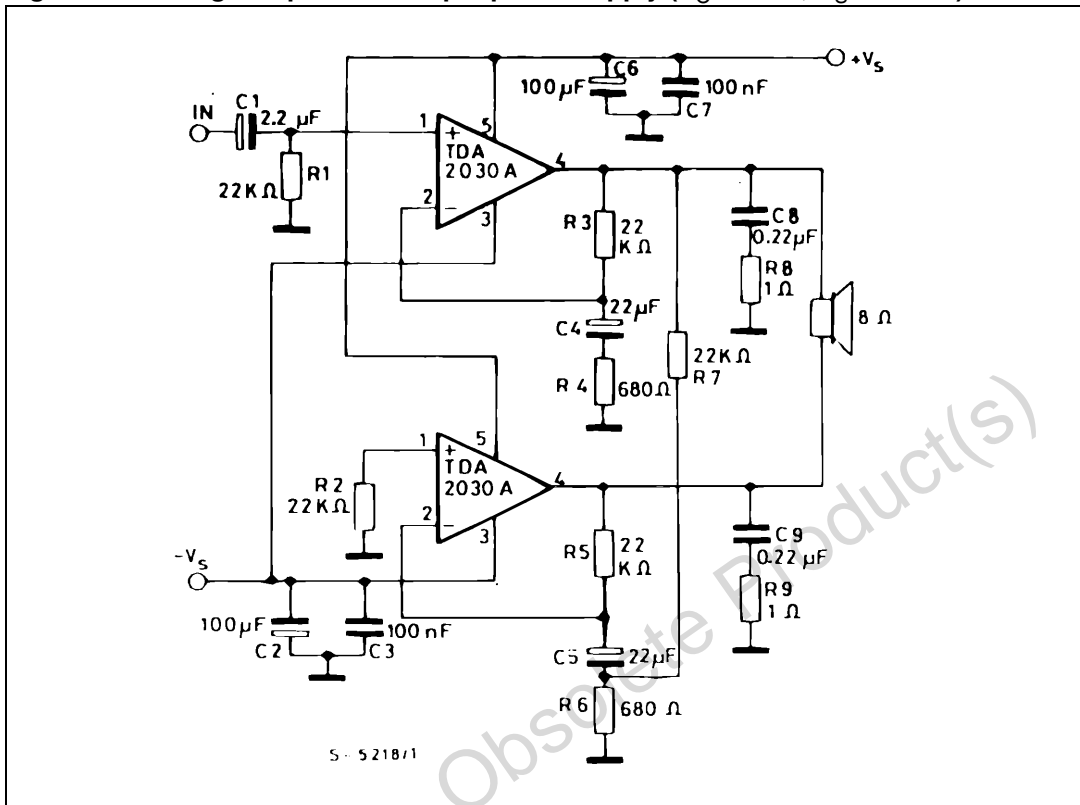
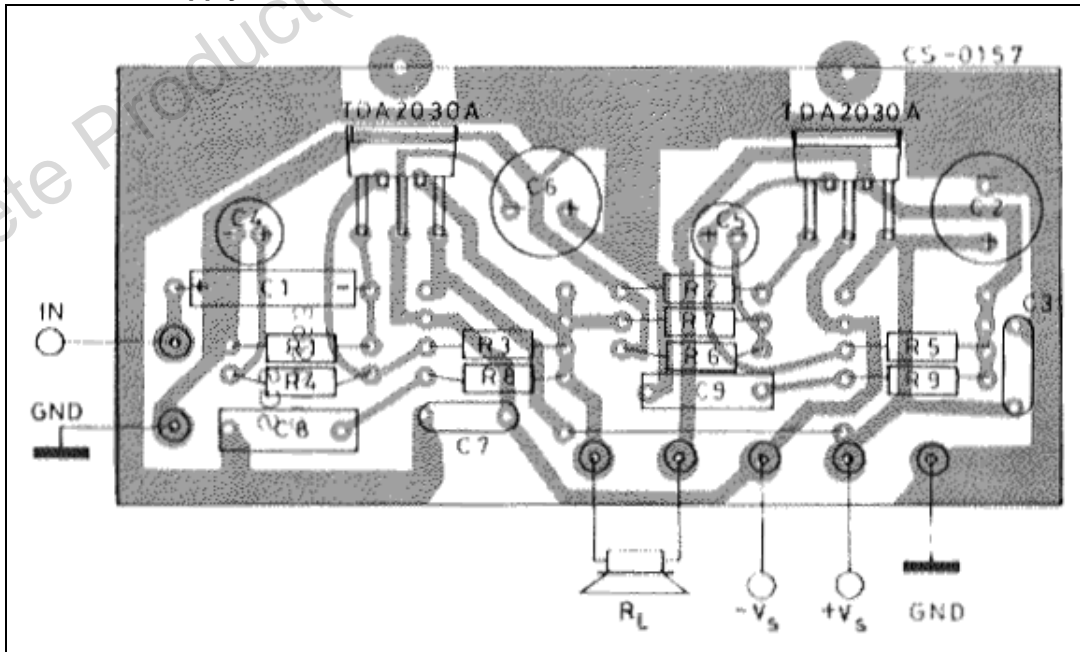

Figure 20. PC board and component layout for the bridge amplifier with split power supply



2 Multiway speaker systems and active boxes

Multiway loudspeaker systems provide the best possible acoustic performance since each loudspeaker is specially designed and optimized to handle a limited range of frequencies. Commonly, these loudspeaker systems divide the audio spectrum into two or three bands.

To maintain a flat frequency response over the hi-fi audio range, the bands covered by each loudspeaker must overlap slightly. Imbalance between the loudspeakers produces unacceptable results, therefore it is important to ensure that each unit generates the correct amount of acoustic energy for its segment of the audio spectrum. In this respect it is also important to know the energy distribution of the music spectrum to determine the cutoff frequencies of the crossover filters (see [Figure 21](#)). As an example, a 100 W three-way system with crossover frequencies of 400 Hz and 3 kHz would require 50 W for the woofer, 35 W for the midrange unit and 15 W for the tweeter.

Figure 21. Power distribution vs. frequency

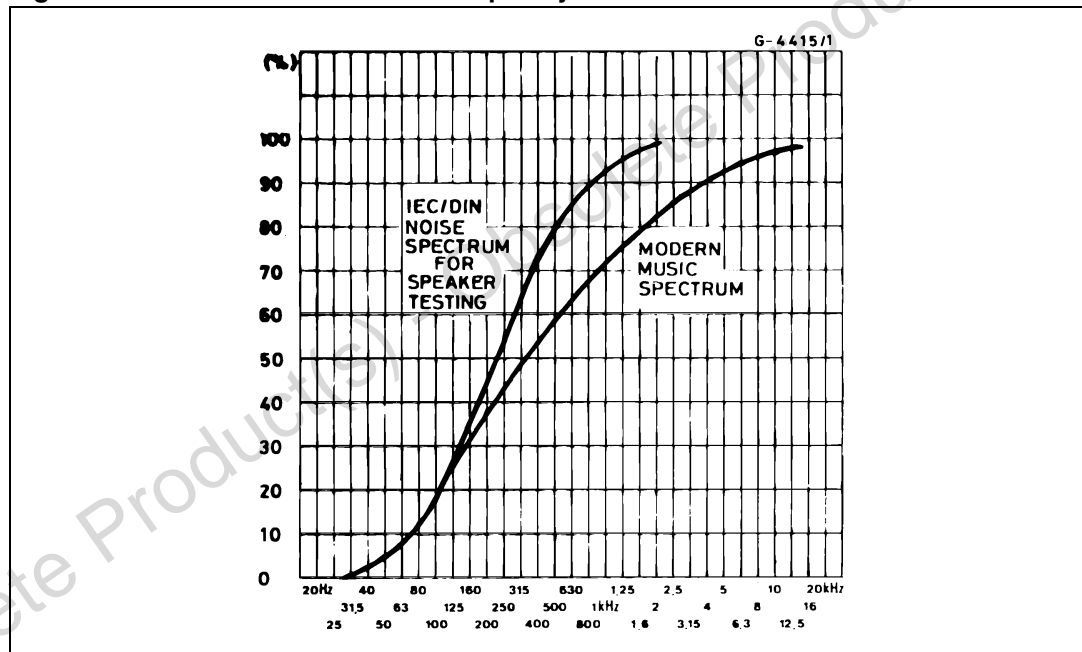

Both active and passive filters can be used for crossovers, but today active filters cost significantly less than a good passive filter using air cored inductors and non-electrolytic capacitors. In addition, active filters do not suffer from the typical defects of passive filters:

- power less
- increased impedance seen by the loudspeaker (lower damping)
- difficulty of precise design due to variable loudspeaker impedance.

Obviously, active crossovers can only be used if a power amplifier is provided for each drive unit. This makes it particularly interesting and economically sound to use monolithic power amplifiers.

In some applications, complex filters are not really necessary and simple RC low-pass and high-pass networks (6 dB/octave) can be recommended. The results obtained are excellent because this is the best type of audio filter and the only one free from phase and transient distortion.

The rather poor out-of-band attenuation of single RC filters means that the loudspeaker must operate linearly well beyond the crossover frequency to avoid distortion.

A more effective solution, "Active Power Filter" by STMicroelectronics is shown in [Figure 22](#).

Figure 22. Active Power Filter

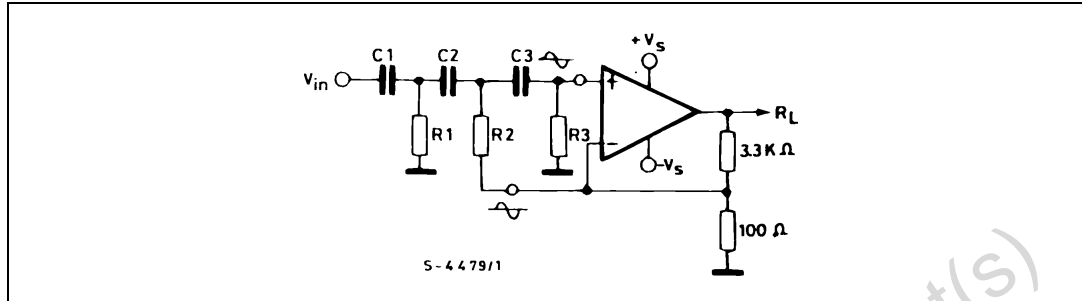

The proposed circuit can realize combined power amplifiers and 12 dB/octave or 18 dB/octave high-pass or low-pass filters.

In practice, at the input pins of the amplifier two equal and in-phase voltages are available, as required for the active filter operation.

The impedance at the pin (-) is of the order of 100 Ω, while that of the pin (+) is very high, which is also what was wanted.

The component values calculated for $f_c = 900$ Hz using a Bessek 3rd order Sallen and Key structure are :

$C_1 = C_2 = C_3$	R_1	R_2	R_3
22 nF	8.2 kΩ	5.6 kΩ	33 kΩ

Using this type of crossover filter, a complete 3-way 60 W active loudspeaker system is shown in [Figure 23](#).

It employs 2nd order Butterworth filters with the crossover frequencies equal to 300 Hz and 3 kHz. The midrange section consists of two filters, a high-pass circuit followed by a low-pass network. With $V_S = 36$ V the output power delivered to the woofer is 25 W at $d = 0.06\%$ (30 W at $d = 0.5\%$).

The power delivered to the midrange and the tweeter can be optimized in the design phase taking in account the loudspeaker efficiency and impedance ($R_L = 4 \Omega$ to 8Ω).

It is quite common that midrange and tweeter speakers have an efficiency 3 dB higher than woofers.

Figure 23. 3-way 60 W active loudspeaker system ($V_S = 36\text{ V}$)

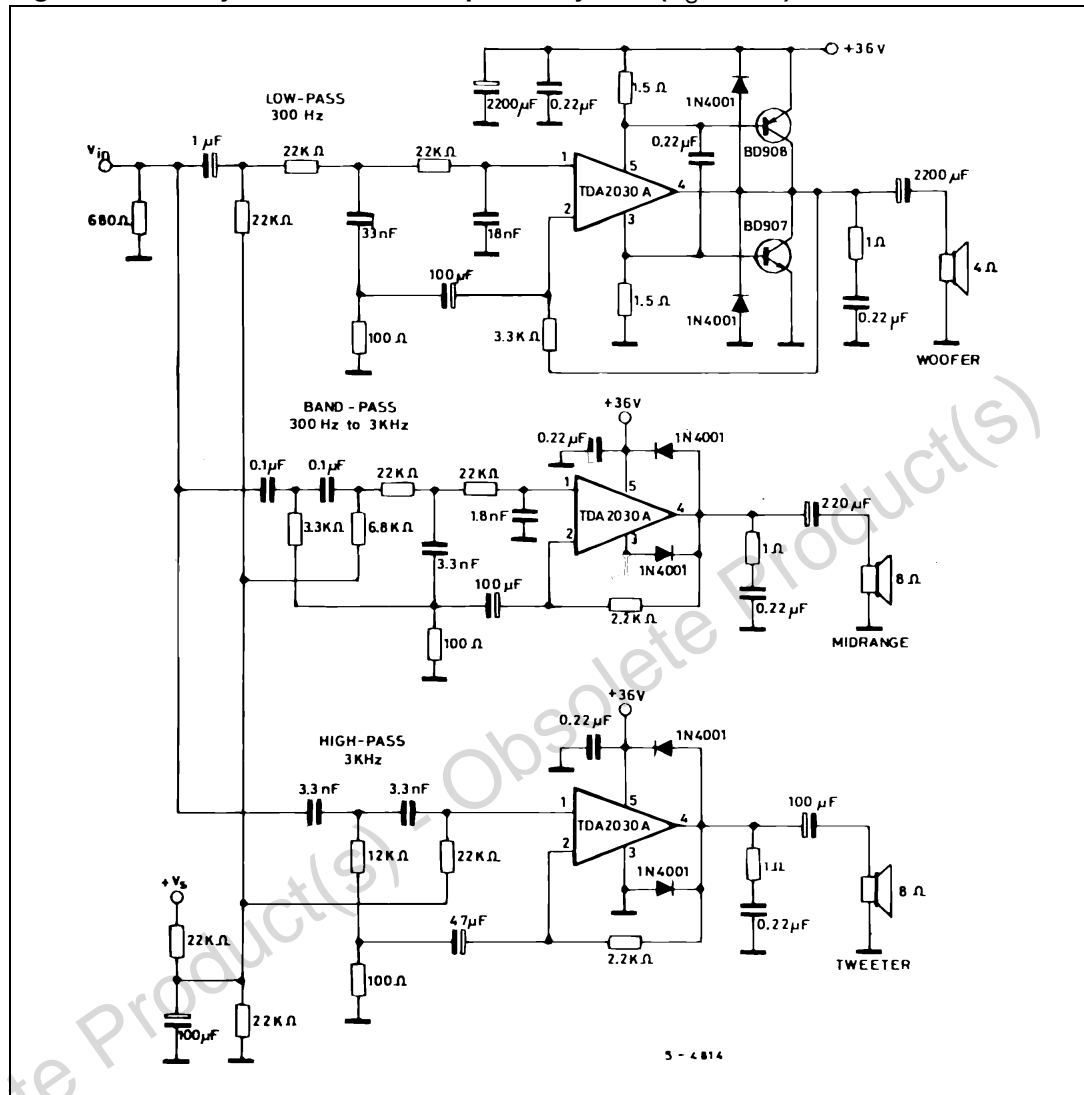

3 Musical instruments amplifiers

Another important field of application for active systems is music.

In this area the use of several medium power amplifiers is more convenient than a single high-power amplifier, and it is also more reliable. A typical example (see [Figure 24](#)) consists of four amplifiers each driving a low-cost, 12-inch loudspeaker. This application can supply 80 to 160 W_{RMS}.

Figure 24. High-power active box for musical instrument

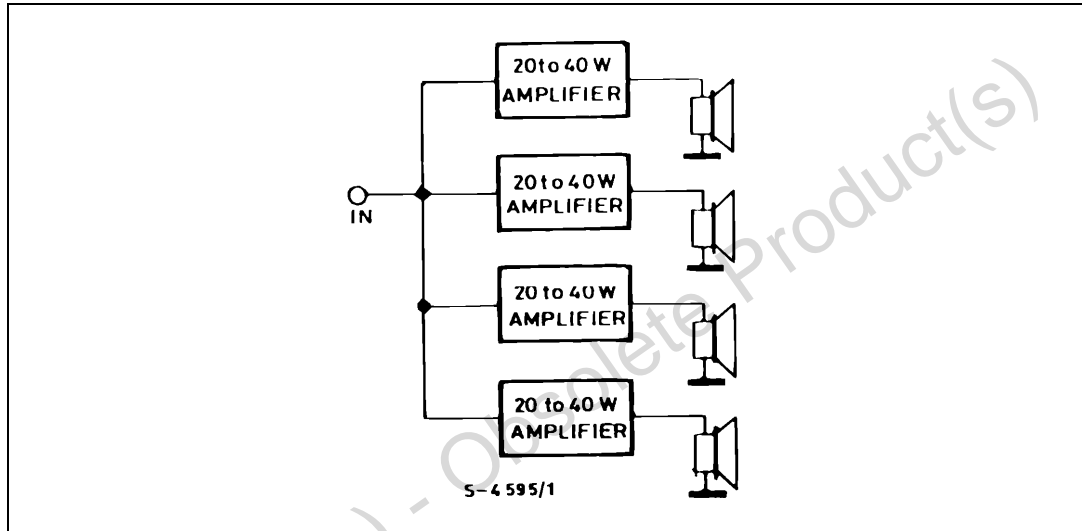

4 Transient intermodulation distortion (TIM)

Transient intermodulation distortion is an unfortunate phenomenon associated with negative-feedback amplifiers. When a feedback amplifier receives an input signal which rises very steeply, i.e. contains high-frequency components, the feedback can arrive too late so that the amplifiers overloads and a burst of intermodulation distortion will be produced as in [Figure 25](#). Since transients occur frequently in music this obviously a problem for the designer of audio amplifiers. Unfortunately, heavy negative feedback is frequently used to reduce the total harmonic distortion of an amplifier, which tends to aggravate the transient intermodulation (TIM situation). The best known method for the measurement of TIM consists of feeding sine waves superimposed onto square waves, into the amplifier under test. The output spectrum is then examined using a spectrum analyser and compared to the input. This method suffers from serious disadvantages : the accuracy is limited, the measurement is a rather delicate operation and an expensive spectrum analyser is essential. A new approach applied by STMicroelectronics to monolithic amplifiers measurement is fast, cheap (it requires nothing more sophisticated than an oscilloscope) and sensitive - and it can be used for values as low as 0.002% in high-power amplifiers.

Figure 25. Overshoot phenomenon in feedback amplifiers

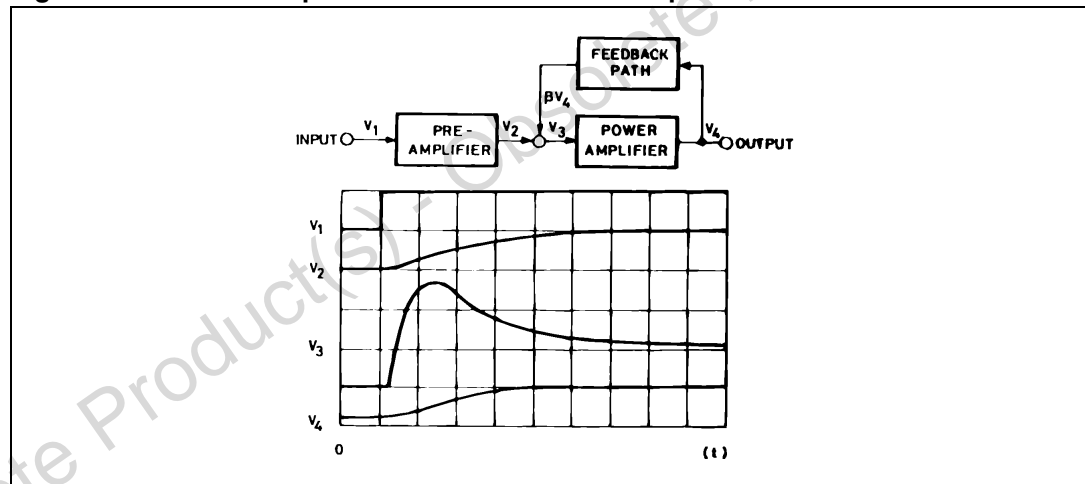

The "inverting-sawtooth" method of measurement is based on the response of an amplifier to a 20 kHz sawtooth waveform. The amplifier has no difficulty following the slow ramp, but it cannot follow the fast edge. The output will follow the upper line in [Figure 26](#) cutting of the shaded area and thus increasing the mean level. If this output signal is filtered to remove the sawtooth, direct voltage remains which indicates the amount of TIM distortion, although it is difficult to measure because it is indistinguishable from the DC offset of the amplifier. This problem is neatly avoided in the IS-TIM method by periodically inverting the sawtooth waveform at a low audio frequency as shown in [Figure 27](#).

Figure 26. 20 kHz sawtooth waveform

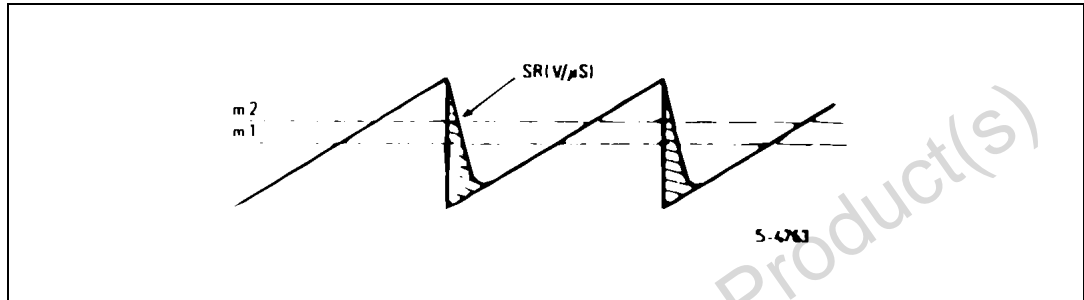
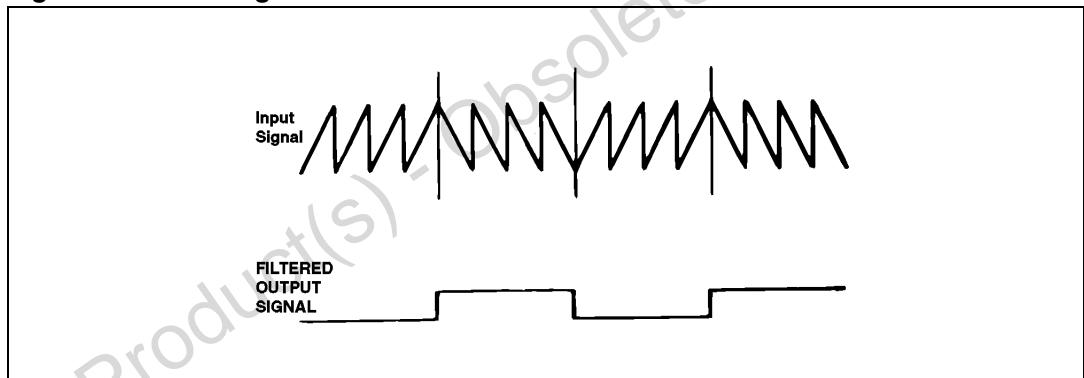

Figure 27. Inverting sawtooth waveform



In the case of the sawtooth in [Figure 27](#) the mean level was increased by the TIM distortion, for a sawtooth in the other direction, the opposite is true. The result is an AC signal at the output whose peak-to-peak value is the TIM voltage, which can be measured easily with an oscilloscope. If the peak-to-peak value of the signal and the peak-to-peak of the inverting sawtooth are measured, the TIM can be found very simply from:

$$\text{TIM} = \frac{V_{\text{OUT}}}{V_{\text{sawtooth}}} \cdot 100$$

In [Figure 28](#) the experimental results are shown for the 30 W amplifier using the TDA2030A as a driver and a low-cost complementary pair. A simple RC filter on the input of the amplifier to limit the maximum signal slope (SS) is an effective way to reduce TIM.

Figure 28. TIM distortion versus output power

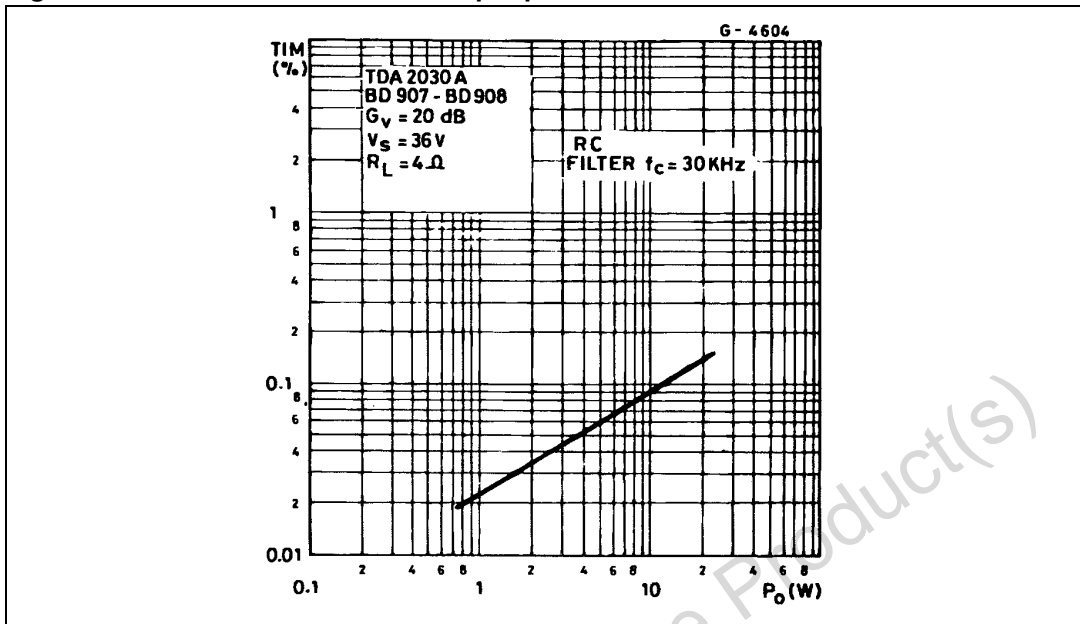

The diagram of [Figure 29](#) originated by STMicroelectronics can be used to find the slew rate (SR) required for a given output power or voltage and a TIM design target.

For example if an anti-TIM filter with a cutoff at 30 kHz is used and the max. peak-to-peak output voltage is 20 V then, referring to the diagram, a slew rate of 6 V/ms is necessary for 0.1% TIM. As shown slew rates of above 10 V/ms do not contribute to a further reduction in TIM.

Slew rates of 100 V/ms are not only useless but also a disadvantage in hi-fi audio amplifiers because they tend to turn the amplifier into a radio receiver.

Figure 29. TIM design diagram ($f_c = 30 \text{ kHz}$)

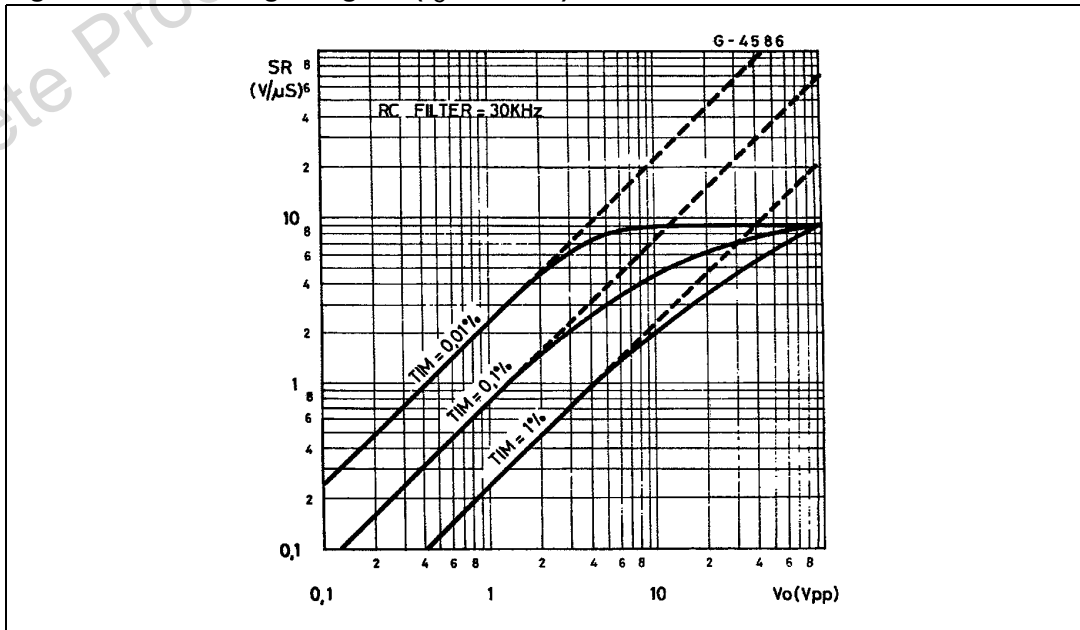

5 Power supply

Using a monolithic audio amplifier with non-regulated supply voltage, it is important to design the power supply correctly. For any operation it must provide a supply voltage less than the maximum value fixed by the IC breakdown voltage.

It is essential to take into account all the operating conditions, in particular mains fluctuations and supply voltage variations with and without load. The TDA2030A (VS max = 44 V) is particularly suitable for substitution of the standard IC power amplifiers (with VS max = 36 V) for more reliable applications. An example, using a simple full-wave rectifier followed by a capacitor filter, is shown in [Table 6](#) and in the diagram of [Figure 30](#).

Figure 30. DC characteristics of 50 W non-regulated supply

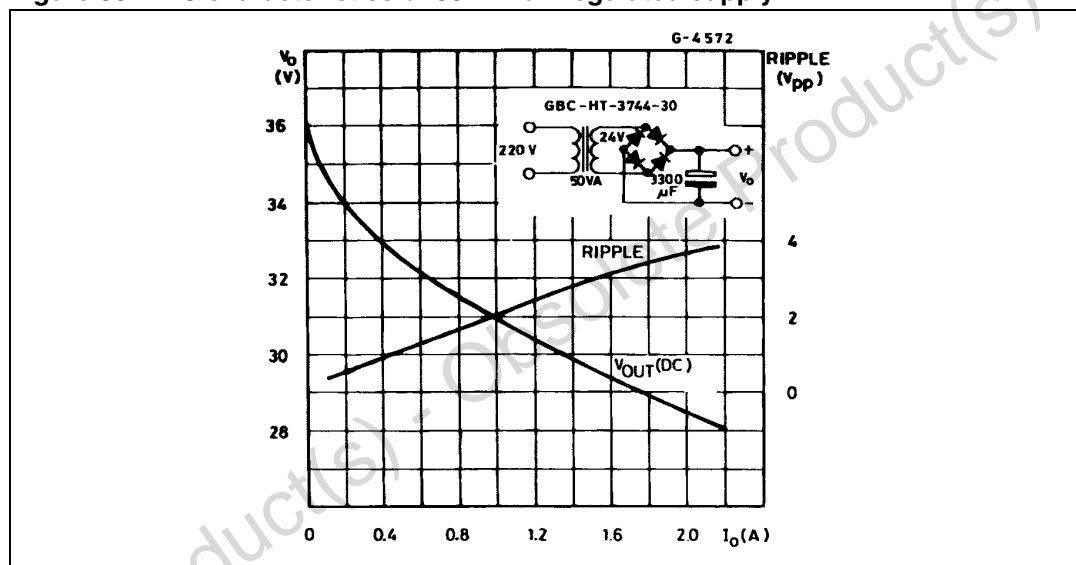

Table 6. DC characteristics of 50 W non-regulated supply

Mains (220 V)	Secondary voltage	DC output voltage (Vo)		
		Io = 0	Io = 0.1 A	Io = 1 A
+ 20%	28.8 V	43.2 V	42 V	37.5 V
+ 15%	27.6 V	41.4 V	40.3 V	35.8 V
+ 10%	26.4 V	39.6 V	38.5 V	34.2 V
-	24 V	36.2 V	35 V	31 V
- 10%	21.6 V	32.4 V	31.5 V	27.8 V
- 15%	20.4 V	30.6 V	29.8 V	26 V
- 20%	19.2 V	28.8 V	28 V	24.3 V

A regulated supply is not usually used for the power output stages because its dimensioning must be done taking into account the power to supply in the signal peaks. They are only a small percentage of the total music signal, with consequently large overdimensioning of the circuit.

Even if, with a regulated supply, higher output power can be obtained (V_S is constant in all operating conditions), the additional cost and power dissipation do not usually justify its use. Using non-regulated supplies, there are fewer design restrictions. In fact, when signal peaks are present, the capacitor filter acts as a flywheel, supplying the required energy. In average conditions, the continuous power supplied is lower. The music power/continuous power ratio is greater in this case than for the case of regulated supply, with space saving and cost reduction.

Obsolete Product(s) - Obsolete Product(s)

6 Application recommendation

The recommended values of the components are those shown in the application circuit of [Figure 17](#). Different values can be used, please refer to the guidelines in [Table 7](#).

Table 7. Recommended values of components for a typical amplifier

Comp.	Recom. value	Purpose	Larger than recommended value	Smaller than recommended value
R1	22 kΩ	Closed loop gain setting	Increase of gain	Decrease of gain
R2	680 Ω	Closed loop gain setting	Decrease of gain ⁽¹⁾	Increase of gain
R3	22 kΩ	Non inverting input biasing	Increase of input impedance	Decrease of input impedance
R4	1 Ω	Frequency stability	Danger of oscillation at high frequencies with inductive loads	
R5	≅ 3 R2	Upper frequency cutoff	Poor high-frequency attenuation	Danger of oscillation
C1	1 μF	Input DC decoupling		Increase of low-frequency cutoff
C2	22 μF	Inverting DC decoupling		Increase of low-frequency cutoff
C3, C4	0.1 μF	Supply voltage bypass		Danger of oscillation
C5, C6	100 μF	Supply voltage bypass		Danger of oscillation
C7	0.22 μF	Frequency stability		Larger bandwidth
C8	$\cong \frac{1}{2\pi BR1}$	Upper frequency cutoff	Smaller bandwidth	Larger bandwidth
D1, D2	1N4001	To protect the device against output voltage spikes		

1. The value of closed loop gain must be higher than 24 dB.

7 Protections

7.1 Short-circuit protection

The TDA2030A has an original circuit which limits the current of the output transistors. This function can be considered as being peak power limiting rather than simple current limiting. It reduces the possibility that the device gets damaged during an accidental short-circuit from AC output to ground.

7.2 Thermal shutdown

The presence of a thermal limiting circuit offers the following advantages:

1. An overload on the output (even if it is permanent), or an above-limit ambient temperature can be easily supported since T_j cannot be higher than 150 °C.
2. The heatsink can have a smaller factor of safety compared with that of a conventional circuit. There is no possibility of device damage due to high junction temperature. If, for any reason, the junction temperature increases up to 150 °C, the thermal shutdown simply reduces the power dissipation and the current consumption.

Figure 31. Pentawatt (vertical) mechanical data and package dimensions

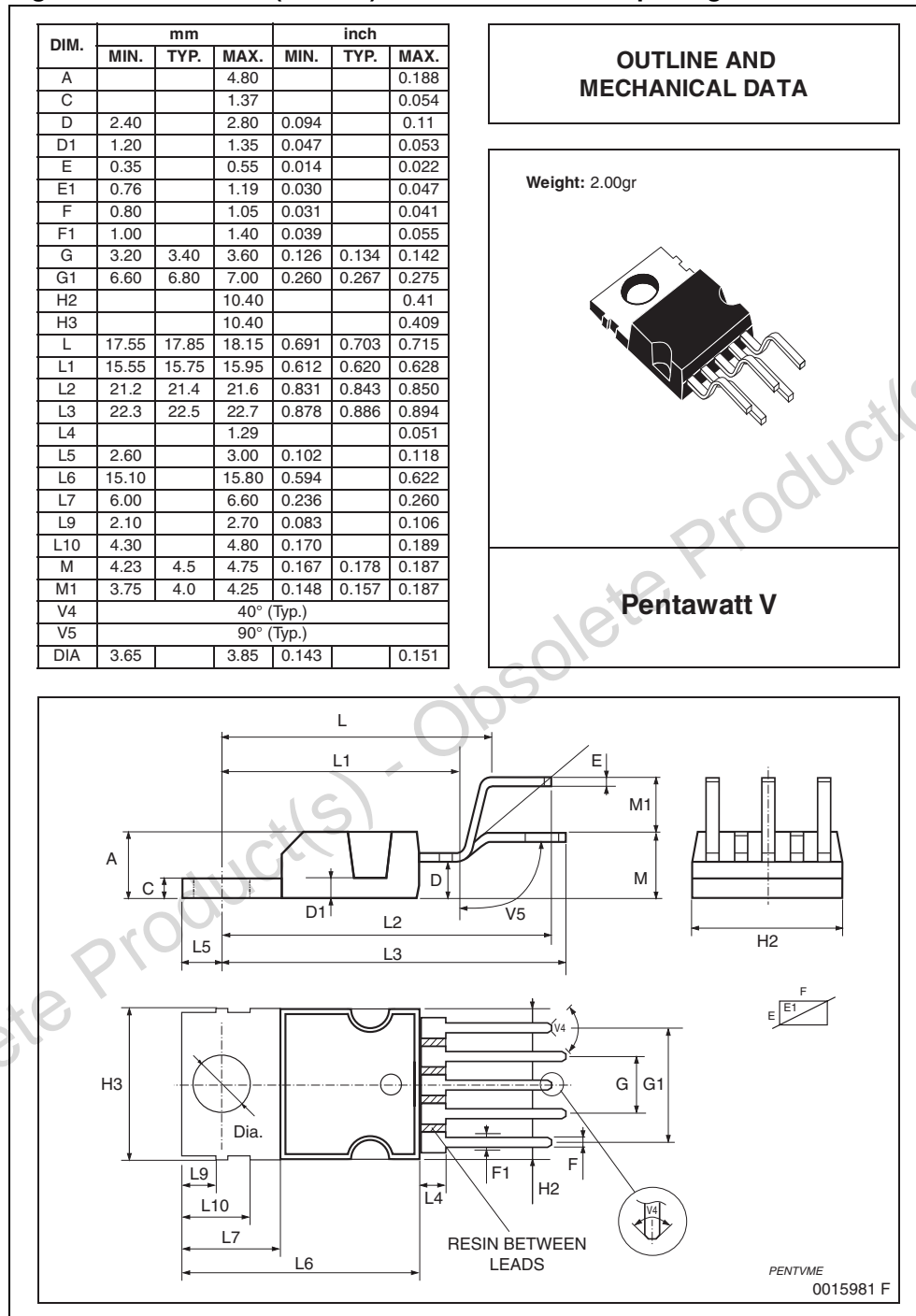

In order to meet environmental requirements, ST offers these devices in different grades of ECOPACK® packages, depending on their level of environmental compliance. ECOPACK® specifications, grade definitions and product status are available at: www.st.com. ECOPACK® is an ST trademark.

8 Revision history

Table 8. Document revision history

Date	Revision	Changes
Oct-2000	1	Initial release.
13-Jul-2011	2	Added Features Added Table 1: Device summary Removed minimum value from Pentawatt (vertical) package dimension H3 (Figure 31) Revised general presentation, minor textual updates

Obsolete Product(s) - Obsolete Product(s)

Please Read Carefully:

Information in this document is provided solely in connection with ST products. STMicroelectronics NV and its subsidiaries ("ST") reserve the right to make changes, corrections, modifications or improvements, to this document, and the products and services described herein at any time, without notice.

All ST products are sold pursuant to ST's terms and conditions of sale.

Purchasers are solely responsible for the choice, selection and use of the ST products and services described herein, and ST assumes no liability whatsoever relating to the choice, selection or use of the ST products and services described herein.

No license, express or implied, by estoppel or otherwise, to any intellectual property rights is granted under this document. If any part of this document refers to any third party products or services it shall not be deemed a license grant by ST for the use of such third party products or services, or any intellectual property contained therein or considered as a warranty covering the use in any manner whatsoever of such third party products or services or any intellectual property contained therein.

UNLESS OTHERWISE SET FORTH IN ST'S TERMS AND CONDITIONS OF SALE ST DISCLAIMS ANY EXPRESS OR IMPLIED WARRANTY WITH RESPECT TO THE USE AND/OR SALE OF ST PRODUCTS INCLUDING WITHOUT LIMITATION IMPLIED WARRANTIES OF MERCHANTABILITY, FITNESS FOR A PARTICULAR PURPOSE (AND THEIR EQUIVALENTS UNDER THE LAWS OF ANY JURISDICTION), OR INFRINGEMENT OF ANY PATENT, COPYRIGHT OR OTHER INTELLECTUAL PROPERTY RIGHT.

UNLESS EXPRESSLY APPROVED IN WRITING BY TWO AUTHORIZED ST REPRESENTATIVES, ST PRODUCTS ARE NOT RECOMMENDED, AUTHORIZED OR WARRANTED FOR USE IN MILITARY, AIR CRAFT, SPACE, LIFE SAVING, OR LIFE SUSTAINING APPLICATIONS, NOR IN PRODUCTS OR SYSTEMS WHERE FAILURE OR MALFUNCTION MAY RESULT IN PERSONAL INJURY, DEATH, OR SEVERE PROPERTY OR ENVIRONMENTAL DAMAGE. ST PRODUCTS WHICH ARE NOT SPECIFIED AS "AUTOMOTIVE GRADE" MAY ONLY BE USED IN AUTOMOTIVE APPLICATIONS AT USER'S OWN RISK.

Resale of ST products with provisions different from the statements and/or technical features set forth in this document shall immediately void any warranty granted by ST for the ST product or service described herein and shall not create or extend in any manner whatsoever, any liability of ST.

ST and the ST logo are trademarks or registered trademarks of ST in various countries.

Information in this document supersedes and replaces all information previously supplied.

The ST logo is a registered trademark of STMicroelectronics. All other names are the property of their respective owners.

© 2011 STMicroelectronics - All rights reserved

STMicroelectronics group of companies

Australia - Belgium - Brazil - Canada - China - Czech Republic - Finland - France - Germany - Hong Kong - India - Israel - Italy - Japan - Malaysia - Malta - Morocco - Philippines - Singapore - Spain - Sweden - Switzerland - United Kingdom - United States of America

www.st.com

Mouser Electronics

Authorized Distributor

Click to View Pricing, Inventory, Delivery & Lifecycle Information:

[STMicroelectronics:](#)

[TDA2030AV](#) [TDA2030AH](#)